

PADDY
CLEANERS® **Ürün Kodu/Product Code /Код продукта**
TURBO PAD 200

PLASTER PİRİNÇ ELEĐİ
PLASTER RICE SIEVE



BEYAMACHINE
SEED PROCESSING

FOTOSORTER®
RENK AYIRMA MAKİNESİ

ARÉCOLTE
DUMONDE

EXCELL CLEANERS®

Fabrika/Factory: Mersin Tarsus 2. Organize Sanayi Bölgesi Rasim Dokur Bulvarı No: 19 Akdeniz MERSİN/TURKEY

www.selectionmachines.com

Gsm: +90 506 761 14 43

E-mail: yalcinokat@selectionmachines.com



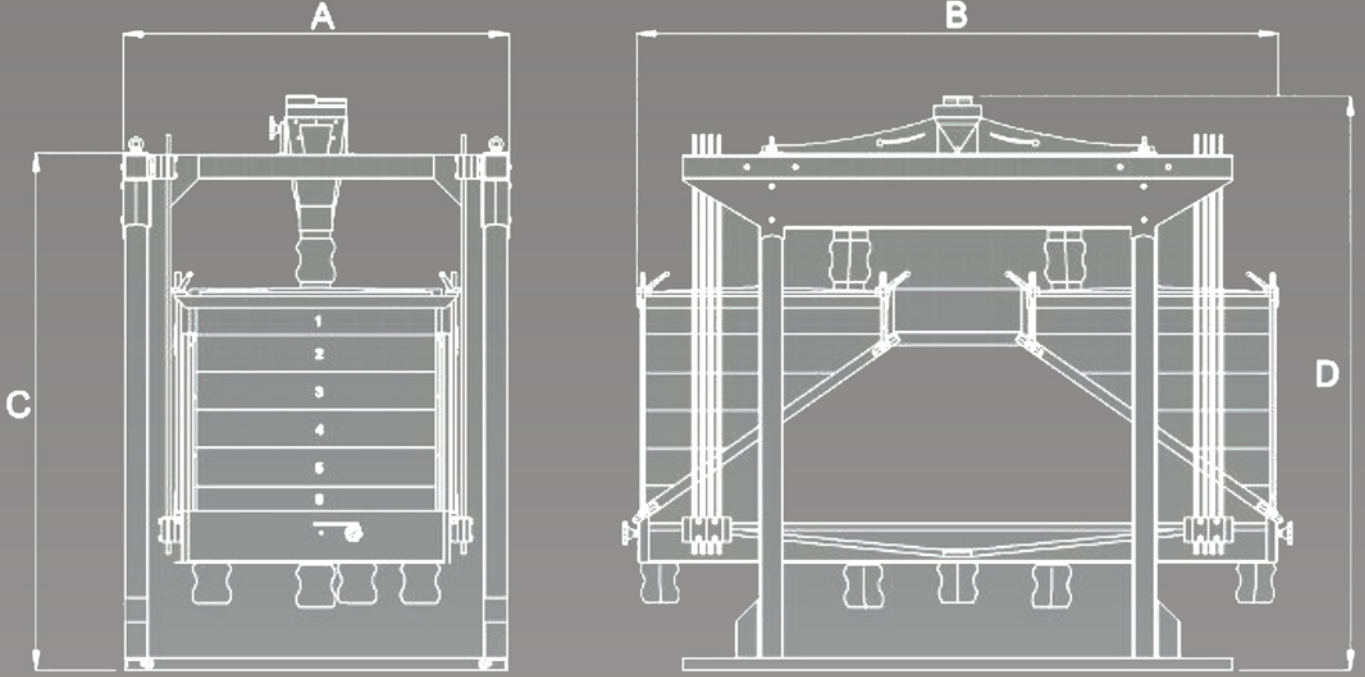

Teknik Özellikler Technical Specifications		Makina Ölçüleri Machine Dimensions				Hacim (M ³) Volume (M ³)	Ağırlık (Kg) Weight (Kg)
Kapasite / Capacity	Motor / Motor	A (mm)	B (mm)	C (mm)	D (mm)		
4500 Kg	3 KW	1600	2765	2160	2395	10,65	1520

Plaster rice sieve machines are the machines which provide the rice to be classified as dust, sand, dust broken, zero broken, cutten broken and rice in the paddy processing plants.

Plaster rice sieve, makes the process of classifying the rice seperated from the dandruff and polished. Plaster rice sieve delivers the rice to two sides in balance via product delivering box. The machine classifies the rice which is spread over the sieve according to the sizes of the pores on the sieve, by using circular vibrations. The rice remained on the sieve ; thanks to the product exit ways stated in the sieve box; moves towards the exit reservoir. The rice that falls down from the sieve pores; starts to sieve in the second sieve. In the same way; with the product exit ways ; the rice sieved in the second sieve and remained ones on the second sieve box; is transported to product exit reservoir. After the rice enters the machine; it becomes sieved in the sieve system. As a result the rice is transported from the rice exit reservoir; the broken rice is from the broken rice reservoir, when it comes to the zero broken one; it is transported from the zero broken exit reservoir.

PADDY
CLEANERS® **ÜRÜN KODU/Product Code /Код продукта**
TURBO PAD 200

PLASTER PİRİNÇ ELEĞİ
PLASTER RICE SIEVE

